

TECHNICAL DATA

Electrical

Impedance	50 Ω
Frequency range	0~6 GHz
Working voltage	1000 Vrms
Insulation resistance	≥5000MΩ

Mechanical & Environmental

Durability (matings)	>500
Temperature range	-55 °C ~ +165 °C
RoHS Compliant	Yes

Material & Finish

Body	Brass, Nickel-plated
Pin Contact	Phosphor Bronze, Gold-plated
Fastening Nut	Brass, Nickel-plated
Crimp Ferrule	Copper, Nickel-plated
Insulator	PTFE
Gasket	Silicone Rubber

Interface Standards

N	IEC-60169
---	-----------

REVISIONS				
REV	DESCRIPTION OF REVISION	ECN No.	DATE	APPROVED
A	INITIAL RELEASE		11/08/2016	M. Dong

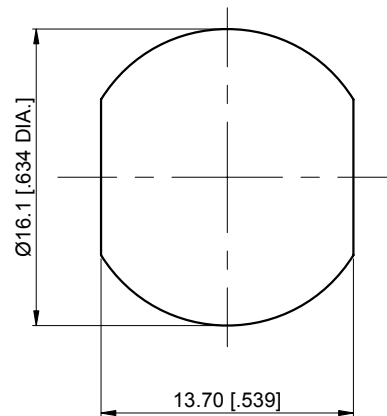
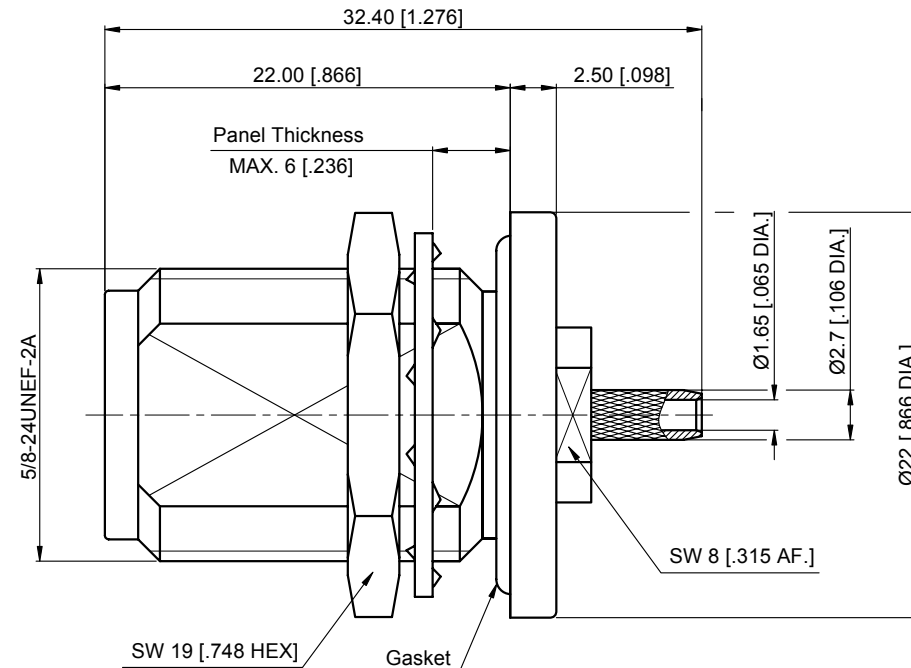

Recommend Mounting Hole

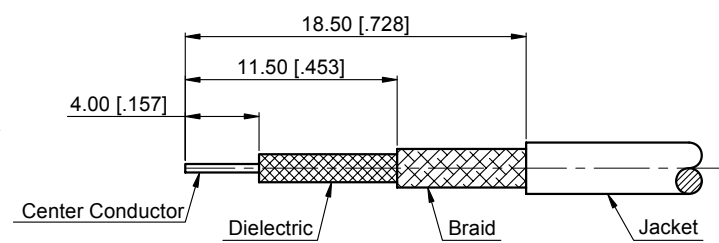

Recommended Cable Stripping Dimensions

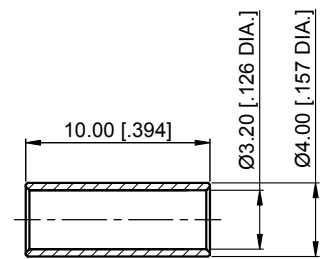

1. CRIMP FERRULE
HEX. CRIMP TOOL SIZE: 3.25 [.128]

- NOTES:
- ALL SPECIFICATIONS ARE SUBJECT TO CHANGE WITHOUT NOTICE AT ANY TIME
 - UNLESS OTHERWISE SPECIFIED ALL DIMENSIONS ARE NOMINAL.

UNLESS OTHERWISE SPECIFIED, DIMENSIONS ARE IN MILLIMETERS [INCHES]. UNLESS OTHERWISE SPECIFIED DIMENSIONAL TOLERANCES ARE: .XX ±0.13 [.005"] .X ±0.20 [.008"] X ±0.50 [.019"] ANGULAR TOLERANCES ARE: ALL±1° DO NOT SCALE DRAWING PROJECTION:
--

DRAWN:	L. Ma	11/08/2016
CHECKED:	J. Zhu	11/08/2016
APPROVED:	M. Dong	11/08/2016

TITLE:
**N Straight Waterproof Bulkhead
Female Crimp for
LMR100/RG174/RG316 Cable**

CMP TER[®]
Cmptter Electronics Co., Ltd. www.cmptter.com

PART No.:
50-02-1D00-175

SIZE: A4	SCALE: 2.5:1	SHEET: 1/1	REV: A
----------	--------------	------------	--------